

MICRO GAS TURBINE CYCLE HUMIDIFICATION FOR INCREASED FLEXIBILITY: NUMERICAL AND EXPERIMENTAL VALIDATION OF DIFFERENT STEAM INJECTION MODELS

Ward De Paepe*

University of Mons (UMONS)
Thermal Engineering and Combustion Unit
Place du Parc 20
7000 Mons, Belgium

Massimiliano Renzi

Free University of Bozen/Bolzano
Faculty of Science and Technology
Piazza Università 1
Bolzano 39100 Italy

Marina Montero Carrero

Vrije Universiteit Brussel (VUB)
Department of Mechanical Engineering
Pleinlaan 2
1050 Brussel, Belgium

Carlo Caligiuri

Free University of Bozen/Bolzano
Faculty of Science and Technology
Piazza Università 1
Bolzano 39100 Italy

Francesco Contino

Vrije Universiteit Brussel (VUB)
Department of Mechanical Engineering
Pleinlaan 2
1050 Brussel, Belgium

ABSTRACT

With the current shift from centralized to more decentralized power production, new opportunities arise for small-scale Combined Heat and Power (CHP) production units like micro Gas Turbines (mGTs). However, to fully embrace these opportunities, the current mGT technology has to become more flexible in terms of operation — decoupling the heat and power production in CHP mode — and in terms of fuel utilization — showing flexibility in the operation with different Lower Heating Value (LHV) fuels. Cycle humidification e.g. by performing steam injection, is a possible route to handle these problems. Current existing simulation models are able to correctly assess the impact of humidification on the cycle performance, but they fail to provide detailed information on the combustion process. To fully quantify the potential of cycle humidification, more advanced numerical models — preferably validated — are necessary. These models are not only capable of correctly predicting the cycle performance, but they can also handle the complex chemical kinetics in the combustion chamber.

In this paper, we compared and validated such a model with a typical steady-state model of the steam injected mGT cycle based on the Turbec T100. The advanced one is an in-house MATLAB® model, based on the NIST database for the characterization of the properties of the gaseous compounds with the combustion mechanisms embedded according to the Gri-MEch 3.0 library. The validation one was constructed using commercial software (Aspen® Plus), using the more advanced RKS-BM property method and assuming complete combustion by using a Gibbs reactor. Both models were compared considering steam injection in the compressor outlet or in the combustion chamber, focussing only on the global cycle performance. Simulation results of the steam injection cycle fuelled with natural gas and syngas showed some differences between the two presented models (e.g. 5.9% on average for the efficiency increase over the simulated steam injection rates at nominal power output for injection in the compressor outlet); however, the general trends that could be observed are consistent. Additionally, the numerical results of the injection in the compressor outlet were also validated with steam-injection experiments in a Turbec T100, in-

*Previous affiliation of this author: Vrije Universiteit Brussel (VUB). Address all correspondence to this author. Email: ward.depaepe@umons.ac.be.

dicating that the advanced MATLAB® model overestimates the efficiency improvement by 25 % to 45 %. The results show the potential of simulating the humidified cycle using more advanced models; however, in future work, special attention should be paid to the experimental tuning of the model parameters in general and the recuperator performance in particular to allow correct assessment of the cycle performance.

NOMENCLATURE

CHP	Combined Heat and Power
GT	Gas Turbine
HRSG	Heat Recovery Steam Generator
LHV	Lower Heating Value
mGT	micro Gas Turbine
mHAT	micro Humid Air Turbine
STIG	STeam-Injected Gas turbine
TIT	Turbine Inlet Temperature
TOT	Turbine Outlet Temperature
VUB	Vrije Universiteit Brussel

INTRODUCTION

To limit the effect of climate change, CO₂ emissions need to be rapidly reduced [1]. One of the measures to decrease them is to shift from classical fossil-based electrical power production to renewable power, using solar, wind and biomass. The share of renewable energy in the total electricity production has fastly increased in the last decades. This puts some constraints on the classical, fossil-based, electrical power generation. Given the highly intermittent nature of renewable energy from solar and wind applications, classical power production has to become more flexible to balance generation and demand and to guarantee grid stability. Together with the shift from classical power to more and more renewables, current energy generation is also shifting from centrally based, with a grid to distribute the power, to more decentralized, possibly in combination with decentralized heat production (Combined Heat and Power (CHP)) [2]. In this framework, new opportunities arise for small-scale CHP units, like micro Gas Turbines (mGTs).

To fully embrace these opportunities, the current mGT has to evolve and become operation and fuel flexible. Operational flexibility consists of the decoupling the heat and power production. Like in most CHP units, in the mGT, thermal and electrical output are produced simultaneously, while the demand for both is usually not coupled. Typically, the mGT is operated in such a way that the heat demand is followed. This means that during periods with little to no heat demand — i.e. during summer period, if the heat is used for external heating purposes —, the mGT needs to be shutdown, leading to longer payback periods [3]. Secondly, the mGT has to become more flexible in terms of fuel utilization: next to the usage of natural gas as primary energy source, in the

shift towards more renewable energy production, alternative fuels with lower energy content — like syngas and biogas — should be used. Given the sometimes limited availability of these fuels, the mGT should be ideally capable of running on both classical fossil-based gaseous fuels — e.g. natural gas with a rather high Lower Heating Value (LHV) — and alternative fuels — e.g. syngas with a rather low LHV. This puts some constraints on the mGT operation (i.e. compressor surge can occur due to the decreasing air mass flow rate, especially when performing load shifts) and the combustion process (i.e. possible combustion instabilities, leading to flameout).

Cycle humidification is a possible route to handle the problem of flexibility both in terms of operational and fuel flexibility. By humidifying the mGT cycle during periods with limited heat demand, the heat that cannot be used for thermal power can be recovered in the cycle [4], increasing the operational flexibility. Additionally, by humidifying the cycle, several problems that arise when using alternative low-LHV fuels, e.g. the risk of reaching very high operating temperatures in the combustion chamber [5] (which could facilitate the formation of pollutants) could be solved. Using a proper injection of steam in specific zones of the combustion chamber should allow regulating the combustion temperature as well as the formation of CO and NO_x [6].

Different options for Gas Turbine (GT) and mGT cycle humidification exist [7]; however, the most straightforward and the one on which we will focus in this paper, is the injection of auto-raised steam in either the compressor outlet or the combustion chamber. A more complete discussion on all different options for cycle humidification for mGT application in general, like direct water injection or evaporative cycles, and their impact on the mGT cycle performance can be found in [8].

Steam injection in mGTs has been studied both numerically and experimentally. Lee et al. were the first to conduct a numerical, comparative study, assessing the difference between liquid water or steam injection before and after the recuperator in a 30 kW_e mGT, showing that steam injection before the recuperator increases the electrical efficiency the most (a relative efficiency increase of 8.6 % compared to 3.8 %) [9]. On the experimental side, Mochizuki et al. were the first to perform an experimental study on steam injection in an mGT cycle. They injected steam, externally generated using a gas boiler, with a steam/air ratio of up to 6 % in the recuperator inlet of a Capstone C60 (60 kW_e) showing that the efficiency increased by 3 to 4 % [10]. Additionally, they showed that, as expected, NO_x emissions decreased (from 4.6 to 1.5 ppm) while a slight increase in CO emissions was reported [10]. Delattin et al. also numerically studied the potential of auto-raised steam injection in the compressor outlet of a Turbec T100, showing that with a maximal injection of 3.3 % steam, the electrical efficiency increased by 5.1 % relative [3]. These numerical results were also obtained by Stathopoulos and Paschereit when simulating steam injection in the same mGT [11] and were finally validated experimentally by De Paepe et al. [12, 13]. Dur-

ing these experiments, an increasing steam flow rate—provided by an external electric boiler—could be injected up to the thermodynamic limit for auto-raised steam, resulting in stable operation at constant power output and Turbine Outlet Temperature (TOT), increased electrical efficiency (5.6 % relative increase when 3.5 % of the air mass flow is replaced with steam) and reduced rotational speed. During these tests, no problems were noticed with the mGT control system, showing the potential of the Turbec T100 for steam injection [12, 13]. To assess the effect of the altered composition of the working fluid on the turbine performance when linking the mGT with a fuel cell, Ferrari et al. conducted experiments injecting superheated steam upstream of the combustor. The test conducted on a Turbec T100 showed a stable mGT operation at constant power output and increased efficiency, but lower rotational speed. Similar to the previous test with steam injection on the same mGT, no problems with combustion or controller instabilities were reported [14]. Finally, Renzi et al. have performed several numerical studies with steam injection in the combustion chamber of a T100, fed with syngas. They found that the maximal auto-raised steam flow rate was 56 g/s (7.5 %), leading to an electrical power production increase of 24 % and an efficiency slightly increasing up to 29 % [6, 5, 15].

Next to the effects of steam injection on the thermal performance of the mGT, several studies have also been published on the economical aspects [3, 16, 11, 17]. Delattin et al. presented the first preliminary analysis of the conversion of a T100 into a Steam-Injected Gas turbine (STIG) proving that at least 5000 hours of dry operation and a minimum of 1500 hours of wet operation are necessary to make steam injection profitable and favourable over the dry mGT [3]. Based on the findings of Lee et al. [9], Loujendi et al. performed an economic analysis for the different injection cases. They however considered that the units would only operate in wet mode (no switching between CHP and STIG mode), concluding that the mGT without steam injection has the shortest payback period. This study clearly indicates mGT humidification should be used in combination with dry CHP operation mode when there is a demand for heat [16]. Finally, the most in-depth economic analysis of the STIG mode on mGTs has been performed by Stathopoulos and Paschereit on a retrofit of a T100 mGT for the German CHP market. They showed that the retrofitted turbine has longer annual operation time and higher electrical energy generation, while it is also an attractive investment for the German CHP market with internal rates of return reaching almost 20 % [11, 17].

The humidification of the mGT, e.g. by performing steam injection, can increase the mGT flexibility; however, to fully quantify the potential of cycle humidification, accurate and validated numerical models are necessary. As shown in the literature review, some numerical and experimental work is already available; nevertheless more accurate models integrating both steam injection and combustion with low-LHV fuels are still missing. Most of the models in the literature treat the combustion chamber as a

black box, while the envisaged model should be able to simulate the complex chemical kinetics in the combustion chamber to cope with the challenges of fuel flexibility. At the same time, it should also be capable of correctly predicting the impact of the changing working fluid composition on the mGT components, to get a correct assessment of the impact of steam injection on the performance.

In this paper, we compared and validated such an advanced humidified mGT model with a typical steady-state model of the steam injected mGT cycle based on the Turbec T100. The advanced model was an in-house MATLAB[®] model, based on the NIST database for the characterization of the properties of the gaseous compounds with the combustion mechanisms embedded according to the Gri-MEch 3.0 library. The validation model was constructed using commercial software (Aspen[®] Plus), using the more advanced RKS-BM property method and assuming complete combustion by using a Gibbs reactor. This means that while the advanced model gives more insight in the combustion process, the second model only treats the combustion chamber as a black box increasing the temperature. Although this first model (MATLAB[®]), is a good candidate for more advanced cycle simulation (it combines chemical kinetics modelling with cycle performance assessment), it has not been validated yet. The Aspen[®] model, on the other hand, has already been validated and proven its value [12, 13], but does not allow for detailed combustion simulation. The final aim of this paper is thus to analyse how the advanced MATLAB[®] model assesses the impact of the fuel and the steam injection on the mGT performance as well as the accuracy obtained by comparing it to the classical Aspen[®] model and validating both models experimentally.

The structure of this paper is as follows: in the first section, both numerical models are presented together with the test rig used for validation. In the *Results* section, the comparison of the results of the numerical models, the experimental validation and the impact of using low-LHV fuels is discussed. Finally, concluding remarks are formulated in the *Conclusion* section, while future perspectives are discussed in the *Future Work* section.

NUMERICAL MODELS AND EXPERIMENTAL SETUP

In this section, an overview of the mGT used in the numerical models, the Turbec T100, is given, followed by a description of the numerical models (both MATLAB[®] and Aspen[®] models). Finally, the experimental setup, used for validation of these steam injection models, is presented.

Turbec T100 mGT

As basis for the numerical and experimental work of this paper, the Turbec T100 (currently the AE-T100) was used. The T100 is a typical mGT consisting of a the recuperated Brayton cycle to achieve high electrical efficiency (30 % [18]). The main

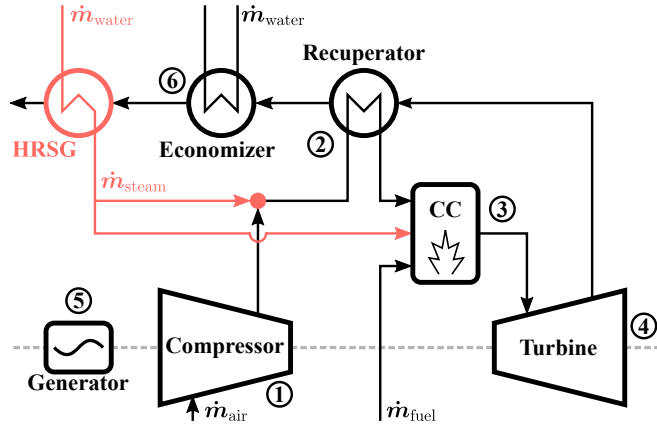

FIGURE 1. The Turbec T100 is a typical recuperated Brayton cycle (black parts), where the air coming from the compressor is preheated in a recuperator by the hot exhaust gases before entering the combustion chamber and turbine. Steam injection in the mGT cycle was simulated in the compressor outlet and in the combustion chamber (red parts).

components of the mGT are, in order of air passage through the cycle (Figure 1, black parts): a variable speed radial compressor (1), a recuperator to preheat the compressed air by using the heat in the exhaust gasses (2), a combustion chamber to increase the temperature to maximal Turbine Inlet Temperature (TIT) of 950 °C (3) and a radial turbine (4) where the hot gas is expanded and, by doing so, delivers mechanical power on the shaft to drive both compressor and electrical generator. Since the T100 is typically used in CHP applications, an economiser (6), producing hot water or steam for heating purpose, is used to recover the remaining heat from the exhaust gasses. The electrical power is generated using a high speed generator (5) and power electronics to convert the power to the grid frequency. The general specification of the Turbec T100 are presented in Table 1 .

Like most mGTs, the T100 operates at constant power output instead of at constant rotational speed as large-scale GTs do. The power output is controlled by changing the rotational speed, in contrast to the power control on larger GTs where inlet guide vanes and TIT control are used. Varying the rotational speed of the mGT allows keeping the compressor efficiency and the mGT electrical efficiency high. Three models of the Turbec T100 (Series 1, 2 and 3), each an upgraded version of the previous one, have been developed. Depending on the version of the T100, the control system does not (Series 1 and 2) or does take into account (Series 3) the electrical power consumed by the natural gas compressor to pressurize the natural gas. As a result, the net power output of the engine depends on the version, as well as the reported efficiency. Since the T100 used for the validation of the wet modelling is a Series 2 (see subsection *Experimental validation*), when simulating the mGT performance for this paper, the power consumed by the fuel compressor is not taken into

TABLE 1. Nominal specifications of the Turbec T100 mGT CHP package, given by the constructor [18].

Nominal electric power	100 kW _e
Nominal thermal power	167 kW _{th}
Nominal electric efficiency	30 %
Nominal thermal efficiency	50 %
Maximal shaft speed	70 000 rpm

account.

Additional to the power control, a second control loop is implemented on the machine, controlling the fuel mass flow rate to keep TIT at its maximal value of 950 °C. The actual control of the fuel flow rate is however based on the measurement of the TOT, since TIT is technically difficult to measure. Therefore, the control system will use the measurement of TOT together with fixed look-up tables to set the fuel flow rate to operate at nominal TIT of 950 °C, which corresponds to a TOT of 645 °C.

Numerical simulation models

In this subsection, the two numerical models—one in-house constructed in MATLAB[®] and the other one developed with the commercial software Aspen[®]—will be presented, discussed and validated. In both models, steam injection in the mGT cycle is simulated in two different locations: injection in the compressor outlet (or recuperator inlet) and in the combustion chamber (Figure 1, red parts).

MATLAB[®] Model Investigations on the main performances of the recuperated Brayton cycle with the basic and the STIG configuration have been carried out using a mathematical model in MATLAB[®] starting from the results obtained in previous studies [19]. The model consists of a set of 86 equations that are solved using a non-linear solver based on Hessian matrices.

The compressor was modelled by computing the final pressure and temperature, which depend on the compressor isentropic efficiency and on the compression ratio. These two parameters can be evaluated thanks to the availability of the compressor and the turbine characteristic maps that were supplied by the manufacturer (Figure 2) and obtained using ambient air as working fluid. The model uses non-linear equations describing the trend of the compression ratio and the isentropic efficiency as a function of the corrected mass flow rate and of the corrected speed. In the equations, also the variation of the working fluid characteristics is taken into account with the ratio of the specific gas constant, for example when changing the typology of fuel used or when the machine operates in a humid cycle.

Compressed air is sent subsequently to the recuperator where it is pre-heated by the exhaust gases exiting the turbine. The

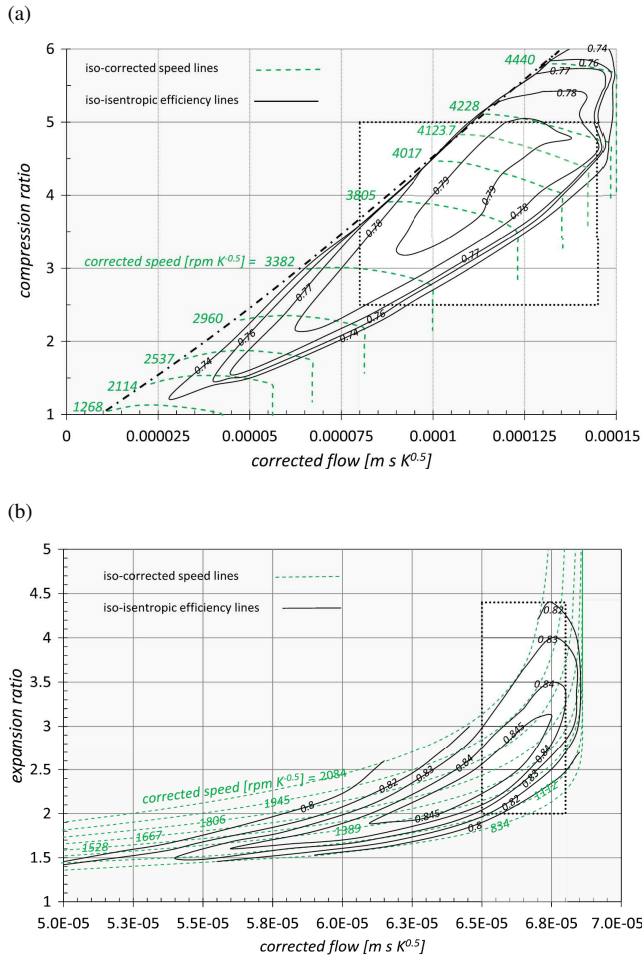

FIGURE 2. For both the Aspen[®] and MATLAB[®] model, compressor and turbine maps provided by the manufacturer have been used.

recuperator performance, in both fresh air and flue gas sides, was evaluated with experimental tests and it was modelled by defining its effectiveness as a function of the mGT rotational speed. In STIG configuration, it is possible to model the mixing of the working fluid with steam either upstream or downstream the recuperator, depending on the desired configuration. The pre-heated air is sent to the combustion chamber where fuel is injected at 6 bar. As mentioned before, several works in literature report that the thermodynamic efficiency can be maximized by introducing steam upstream the recuperator [11, 12]; however, the fuel required to run the mGT in STIG configuration becomes much higher causing the risk of reaching very high operating temperatures in the combustion chamber, which could facilitate the formation of pollutants. A proper injection of steam in specific zones of the combustion chamber should allow reducing the combustion temperature and the formation of CO and NO_x [6].

The combustion process was modelled using the Cantera

TABLE 2. Fixed parameters used in the MATLAB[®] simulation model

Turbine Outlet Temperature (TOT)	[K]	918.15
Organic efficiency	[-]	90 %
Electrical generator efficiency	[-]	95 %
Combustion chamber efficiency	[-]	97 %

MATLAB[®] plug-in, an open source suite for problems involving chemical kinetics, thermodynamics, and/or transport processes [20], with the GRI-MEch 3.0 mechanism [21]. The three combustion zones of the combustor—primary, secondary and dilution zone—are simulated as three different plug flow reactors; the air and fuel intake conditions and flow rates, that represent the boundary conditions of the combustion chamber model, are obtained from the results of the turbocharger model. In terms of pressure variation in the combustion chamber, a 3rd polynomial equation as a function of the mGT rotational speed was used to assess the pressure losses; also in this case the model was validated with experimental tests. The efficiency of the combustion chamber, taking into account the thermal losses was conservatively set equal to 97 %.

As previously mentioned, the turbine performance is assessed with a non-linear equation defining its performance map (Figure 2(b)). A diffuser is placed downstream the turbine that was modelled with a polynomial equation fitting experimental results. No specific assumptions are made on the turbine operation in terms of outlet pressure, except for the TOT that is considered fixed at 645 °C in order to resemble the real control strategy of the fuel mass flow injection of the mGT: a fuel throttling valve acts on the fuel injector in order to keep the temperature downstream the turbine constant. The consumption of the fuel compressor is calculated but not considered in the presented results of the net power output and efficiency.

Finally, the values of the mechanical efficiency, auxiliary efficiency and the power electronics efficiency are considered constant and evaluated by matching the simulation data and the experimental ones; the overall organic efficiency was set equal to 90 % and the electric efficiency to 95 %. Table 2 summarizes again the parameters used in the MATLAB[®] model.

Aspen[®] Plus Model The validation model was constructed in the commercial software Aspen[®] plus process simulator (V9.0) [22]. The model constructed for this paper is an adaptation of a previously developed one [3], of which both the dry [23] and wet operation modes have been experimentally validated [12, 13]. The model has also been used in the past to assess the impact of converting the mGT into a micro Humid Air Turbine (mHAT) cycle [24]. The functioning of the model is briefly explained in following paragraph.

The compressor was modelled using the operating map pro-

vided by the manufacturer (Figure 2(a)). Both constant speed lines and efficiency areas were introduced in the compressor model. Rather than using the map to simulate the turbine performance (Figure 2(b)), the model was simplified by assuming a constant turbine outlet pressure and isentropic efficiency (in dry mode), since turbine efficiency and outlet pressure remained constant over a large variety of parameters [3]. A turbine outlet pressure of 1.05 bar is assumed, which allows the exhaust gases to overcome the head losses in recuperator, economizer and stack. An isentropic efficiency of 85 % is used in dry operating mode, which is corrected for the changing composition of the working fluid when shifting to steam injection, according the recommendations of Parente et al. [25]. The turbine is assumed to be choked. This choking constant is, similar to the turbine efficiency, corrected for the changing working fluid composition in wet operation. Since the turbine is choked, during steam injection, the compressor operating point will shift closer to the surge limit. Part of the air mass flow rate is thus replaced by steam, leading to a reduction in the air mass flow rate passing through the compressor. Previous simulations have however indicated that this surge margin reduction is limited when using natural gas as fuel, given the variable speed operation of the mGT [13]. For both turbine and compressor, a mechanical efficiency of 99 % has been used. The recuperator is simulated as a counterflow heat exchanger, where the surface is adapted to correct for the cross flow in- and outlet sections of the component. A pressure loss of 5 % over the cold side was assumed. The combustion chamber is modelled using a Gibbs reactor, assuming complete combustion and 5 % pressure loss. The different pressure losses used in the Aspen[®] model are based on experimental data and available information in literature on the recuperator [26] and were fine tuned using model optimization based on experimental results. The losses in the generator and power electronics were combined, leading to a total efficiency of the electrical part of 94 %.

The control system of the mGT was implemented in the Aspen[®] model using two *Design Specs*. In a first *Spec*, the power output is kept constant by controlling the rotational speed, while in the second *Spec*, the TOT is kept constant at 645 °C by adjusting the fuel flow rate. Finally, as property method, the Redlich-Kwong-Soave (RKS) cubic equation of state with Boston-Mathias alpha function (RKS-BM) method was used. Previous simulations have indicated that this property method has some difficulties assessing the dew point [4], however this is less crucial for the simulations presented in this paper.

Model comparison Since the aim of this paper is to compare and validate two different models for steam injection in an mGT, a comparison between both models, discussing the main similarities and differences, is presented in Table 3.

For simulation of the steam injection, in both models, two approaches have been used for the different injection positions.

For the numerical simulations of steam injection in the compressor outlet, saturated steam is generated using a heater block, setting 0.1 °C of superheating and an injection pressure equal to the pressure of the air leaving the compressor. This corresponds to the experimental set-up, where saturated steam is injected in the mGT using the small pressure difference between steam boiler and compressor outlet (see later). At the injection point, due to the presence of the steam pipe, an additional pressure loss of 0.5 % was assumed. Injection in the combustion chamber requires a higher steam pressure to allow steady injection. To simulate the steam injection in the combustion chamber, saturated steam at a pressure of 6 bar (same pressure provided by the fuel compressor for fuel injection in the combustion chamber) is produced and injected in the combustion chamber.

Test rig description

For the validation of the steam injection models, experiments have been performed on the humidified Turbec T100 mGT test rig of the Vrije Universiteit Brussel (VUB). This test rig consists of a Turbec T100 Series 2 mGT equipped with a steam injection line to study the impact of steam injection on the cycle performance [12, 13] and a saturation tower to convert the mGT into a mHAT [27] (which was bypassed for the steam injection test for model validation) and a data acquisition system. This test rig has been used to validate the dry performance prediction of the Aspen[®] model in the past [23], while the dry MATLAB[®] model was validated on a different machine [19].

In the experimental setup, rather than using a Heat Recovery Steam Generator (HRSG) to auto-raise steam, the steam is produced using an electrical boiler. This allows for a more flexible steam production and injection. The steam boiler has a nominal power of 100 kW_e, with 3 intermediate power settings allowing to change the steam injection rate. The nominal power output of the boiler was selected based on the maximal amount of steam that could be auto-generated in a HRSG from the available heat in the mGT exhaust gasses. Inside the steam generator, saturated steam is produced. The boiler is connected through a steam pipe with the compressor outlet. On this steam pipe, a liquid separator, a filter, a steam mass flow meter, a check valve, and a regular valve are installed. By setting the pressure inside the steam boiler slightly higher than the pressure after the compressor, an overpressure is created, allowing the injection of steam in the mGT. Finally, the water level is kept constant in the steam boiler using a variable speed pump. This allows keeping the boiler in steady-state conditions, resulting in a constant steam flow rate entering the mGT.

Each steam injection experiment is conducted using the same procedure. First the mGT is started without steam injection. Once steady-state operation is reached, a dry reference is taken by running the mGT dry for approximately 1 hour. After this dry run-in, steam injection is initiated. Steam is always injected at

TABLE 3. Comparison between the modelling of the main mGT components in the Aspen[®] and MATLAB[®] model.

Component	MATLAB [®]	Aspen [®]
Compressor	Operating map provided by the manufacturer (Figure 2(a)).	
Recuperator	In-house model, defining effectiveness as function of the rotational speed, based on experimental results.	Counterflow model using surface and heat exchange coefficient, based on literature [26] and experimental data [23].
Combustion chamber	Detailed kinetic analysis using the Gri-MEch 3.0 library [21].	Gibbs reactor with global energy balance calculation and combustion efficiency.
Turbine	Operating map provided by the manufacturer (Figure 2(b)).	Assumed to be choked with isentropic efficiency corrected for the changing working fluid composition. Values are based on the map provided by the manufacturer (Figure 2(b)).
Property method	NIST database.	RKS-BM method.
Control system	Fuel flow rate control to keep TOT constant at 645 °C. Constant electrical power output control by adjusting the rotational speed.	
Solver	Non-linear solver based on Hessian matrices.	Wegstein and Broyden convergence solvers for closed loops and design specs.

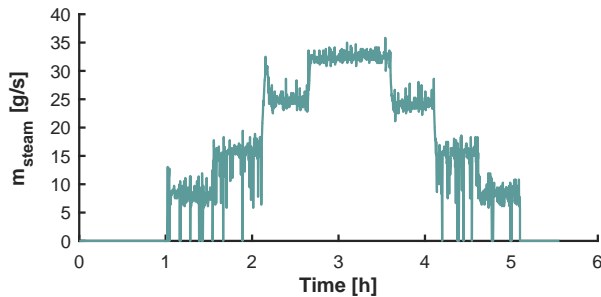
**FIGURE 3.** The steam injection flow rate is gradually increased to avoid any engine shutdown due to flameout in the combustion chamber.

the lowest flow rate, to avoid a too abrupt change in the mGT operation, leading to a flameout and shutdown. Afterwards, the power of the steam boiler is first gradually increased till maximal injection and afterwards gradually decreased, keeping the same injection for at least half an hour to ensure steady-state operation to measure all mGT parameters. The typical progress of a steam injection experiment is presented in Figure 3, showing the injected steam mass flow rate during the experiment. Finally, injection in the combustion chamber is not yet implemented in this test rig.

RESULTS

In this section, the numerical results of both models for steam injection are presented, compared and validated. The impact of

the steam injection was simulated for both full and part-load operation using three different fuels, being L- and H-natural gas and syngas (Table 4). The L-gas composition was taken based on the natural gas provided to the mGT test rig of the VUB [27], while the H-gas composition is equal to the natural gas available for the mGT in Italy [28]. For the syngas, a typical composition obtained when producing the gas from pyrolysis of forestry residual biomass with a very low LHV (8997 kJ/kg), was used. When using this syngas as fuel for the mGT, it is not necessary to remove inert compounds: the resulting gas is simply cleaned to meet the operational requirements of the mGT.

In the following subsections, first the predicted performance for dry and wet operation when using natural gas is compared for both models and injection locations: compressor outlet and in the combustion chamber. This is followed by an experimental validation of the results of steam injection in the compressor outlet. Finally, the impact of syngas feed is assessed for dry and wet operation.

Numerical model comparison for natural gas

In a first step, the predicted performance of the dry mGT of both numerical models, when using natural gas as fuel, has been compared. For both models, the requested power output was varied (Figure 4) as well as the inlet air temperature (Figure 5) to compare the predictions of the mGT performance under different operating conditions. Comparison of the electrical efficiency shows that both models are capable of predicting the dry performance of the mGT; however, there are some differences between

TABLE 4. The composition of the different fuels used for the numerical simulations.

	O ₂	N ₂	CO ₂	CH ₄	C ₂ H ₆	C ₃ H ₈	C ₄ H ₁₀	C ₅ H ₁₂	C ₆ H ₁₄	CO	H ₂	LHV [kJ/kg]
L-gas	0.001	0.137	0.011	0.816	0.029	0.004	0.002	0.001	0.001	0	0	38217
H-gas	0	0	0	0.912	0.067	0.021	0	0	0	0	0	49575
Syngas	0	0.05	0.38	0.21	0	0	0	0	0	0.29	0.07	8997

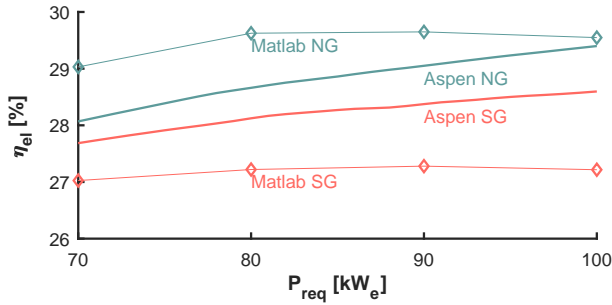
**FIGURE 4.** The predicted performance of the mGT without steam injection at different requested power outputs shows some differences between the MATLAB[®] and the Aspen[®] model, which can be explained by the different implementation of the turbine and parameter tuning.

the models (on average 0.7% absolute difference in electrical efficiency over the simulated power range and 0.1% over the temperature range). When shifting to part load, the difference in simulated efficiency increases (1.0% at 70 kW_e compared to 0.1% at 100 kW_e, Figure 4), while the difference is rather constant and remains very small over the whole simulated temperature range (below 0.2%, Figure 5).

The moderate discrepancies between both models can be explained by the different implementation of the turbine characteristic maps in both numerical models (see Table 3), resulting in slightly different operation of both turbine and compressor and by the fact that the model parameters of both models (especially the recuperator parameters) have been tuned using experimental data of two different versions of the T100. Nevertheless, as mentioned before, these differences are limited, and similar trends can be observed when going from full to part load operation (Figure 4) or when the inlet air temperature increases (Figure 5).

The impact of steam introduction in the mGT cycle was assessed and compared for full (100 kW_e) and part load (90, 80 and 70 kW_e) with a variable steam flow rate using both models (Figure 6¹). The steam injection mass flow rate for both injection in the compressor outlet and the combustion chamber ranged from 0 to 60 g/s. This maximal steam injection flow rate was chosen

¹Only the results of injection at 100 kW_e and 70 kW_e are presented for clarity of the figures; however, similar trends can be observed at intermediate power levels.

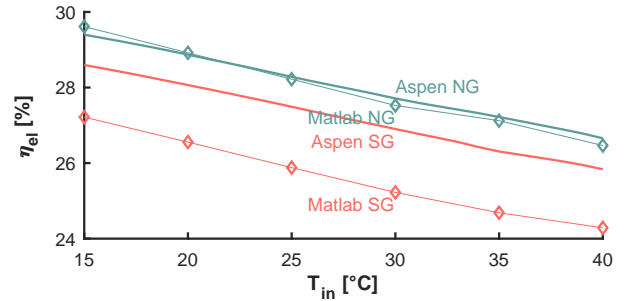
**FIGURE 5.** The dry performance of the mGT at 100 kW_e electrical power output for varying inlet air temperature shows good comparison for both MATLAB[®] and Aspen[®] models.

based on the maximal amount of steam that could be auto-raised at nominal power output when injecting in the compressor outlet (22.5 g/s [3, 12, 13]), the maximal steam flow rate that could experimentally be injected (35 g/s [12, 13]) and the maximal amount that can be auto-raised from the flue gasses when injection occurs in the combustor (56 g/s [5]). Steam injection in the mGT cycle downstream of the compressor — in the compressor outlet or the combustor — leads to a reduced compressor mass flow rate and a shift of the operating point towards surge. This results in a surge margin reduction. However, previous numerical and experimental works done by the authors have shown that this reduction remains limited for the simulated steam flow rates, leaving sufficient surge margin for safe operation [12, 13, 5], which was also noted by other researchers working on the T100 [11, 14]. Given the difference between the predicted dry performance with both models (Figure 4), the predicted impact of steam injection by both models is not compared using absolute injected steam mass flow rate, but rather by using injected steam fraction ($\dot{m}_{\text{steam}}/\dot{m}_{\text{air}}$), which results in a more correct comparison. For each of the injected steam fraction, the relative changes in electrical efficiency ($\Delta\eta_{\text{el}}$), fuel mass flow rate ($\Delta\dot{m}_{\text{fuel}}$) and rotational speed (Δn) are presented in Figure 6. These changes are calculated using a dry reference, obtained with the same model using the same requested power output and inlet conditions.

The results of the simulations using both models (MATLAB[®] versus Aspen[®]) show poor agreement when comparing the impact of steam injection in the compressor outlet on

(a) Steam injection in the compressor outlet.

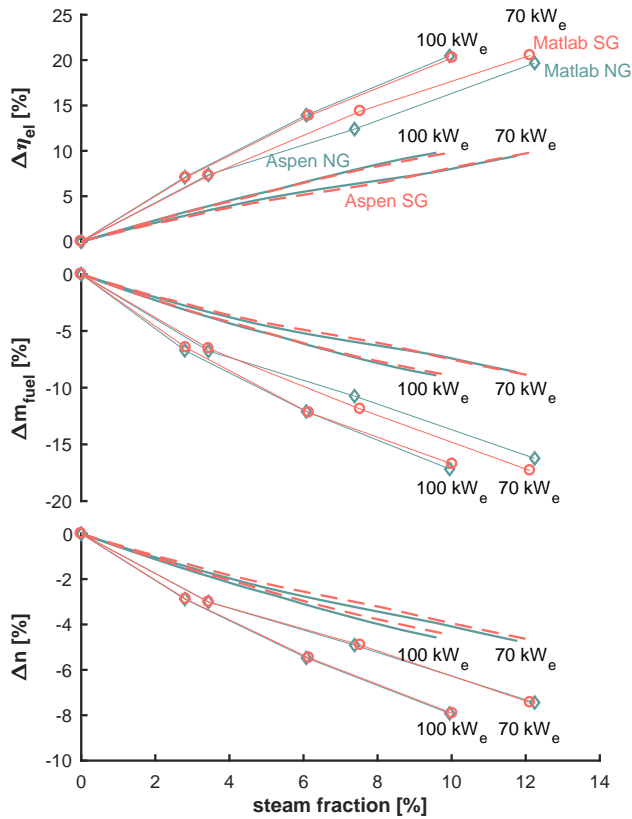

(b) Steam injection in the recuperator outlet

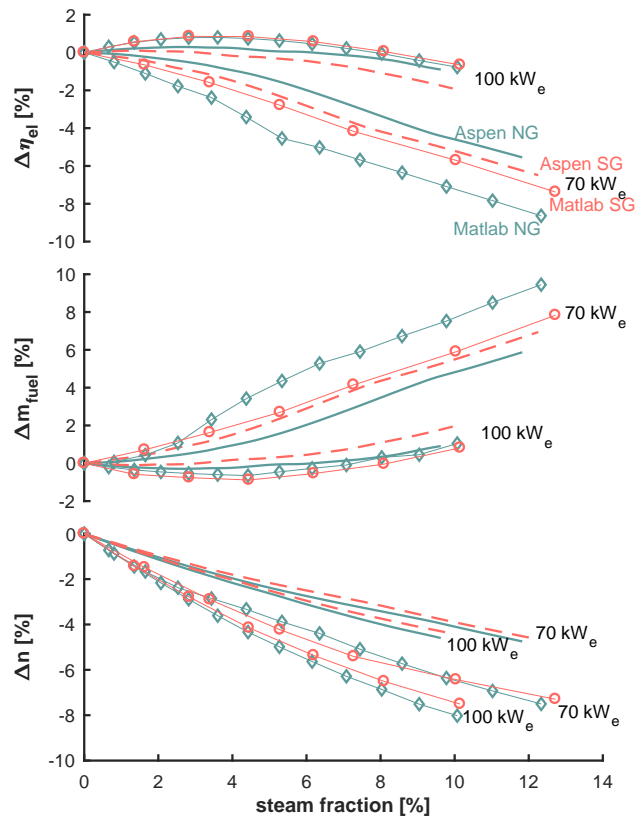

FIGURE 6. Results of steam injection simulations in the compressor outlet (a) and the combustion chamber (b), obtained with the MATLAB[®] (symbols) and Aspen[®] (lines) models, using natural gas (NG) and syngas (SG) show relative good agreement when predicting the impact on the mGT performance.

the electrical efficiency, the fuel consumption and the rotational speed, when natural gas is used as fuel (Figure 6(a)). The differences are however consistent over the full simulation range, for all parameters, at both part (relative differences of 50, 47 and 37 % for the $\Delta\eta_{el}$, $\Delta\dot{m}_{fuel}$ and Δn respectively) and full-load (relative differences of 52, 49 and 40 %). For the injection of steam in the combustion chamber, we can however observe that the simulation results of both models show relative good agreement for the different performance parameters of the mGT. Although both models show relative good agreement for the nominal power output (e.g. an absolute difference of -0.3 , 0.3 and -3.9 % for the $\Delta\eta_{el}$, $\Delta\dot{m}_{fuel}$ and Δn respectively at a steam fraction of 10 % at 100 kW_e), the differences between both models are larger at part load operation (70 kW_e , relative difference of 2.8, 2.7 and -3.0 % for the same parameters at the same steam fraction), which can be explained by the larger difference in the dry reference operation at part load (Figure 4). Since little discrepancies could be observed between the results when using the different natural gas

compositions (L- or H-gas, Table 4), only the results of the L-gas have been shown.

When steam is injected in the compressor outlet, the electrical efficiency rises with increasing steam flow rate (Figure 6(a)). This can be explained by three factors: first, the compressor consumes less power since fewer air passes through this component as steam injection increases; second, the heat recovery in the recuperator increases due to the lower inlet air temperature on the recuperator cold side; third, the heat capacity of the working fluid is larger as a result of steam injection. Therefore, less fuel is consumed in the combustion chamber at constant power output mode, leading to a significant efficiency increase. The relative increase is rather independent of the requested power output (part/full load): The increase is slightly higher at nominal output (2.3 and 1.1 % per injected steam fraction in the MATLAB[®] and Aspen[®] model respectively) compared to part load performance (1.9 and 0.9 % per injected steam fraction). The large deviation between the MATLAB[®] and the Aspen[®] model can be found in

the different implementation of the recuperator (see Table 3). In the MATLAB[®] model, the effectiveness of this component has been tuned based on experimental data. However, in this model, the tuning was done with the original setup of the machine (without steam injection), while in the Aspen[®] model, experimental data was used to update the recuperator performance. Based on the results from Figure 6(a), it is clear that the MATLAB[®] model overestimates the heat recovery in this component, leading to a higher efficiency increase and fuel mass flow rate reduction. A model tuning based on wet experimental data is necessary to achieve a more accurate model of the recuperator.

When steam is injected in the combustion chamber, we observe that the electrical efficiency is reduced (Figure 6(b)). Since the steam is injected after the recuperator, there is no higher heat recovery in the recuperator. On the contrary, the positive effect of the reduced compressor power is eliminated by the higher fuel consumption, due to the lower combustor inlet temperature. More fuel needs to be injected in the combustion chamber to keep the TOT constant (Figure 6(b)). This effect is first limited (at low steam flow rates, the electrical efficiency remains rather constant); however, it becomes more significant at higher flow rates. The effect is more severe at part load operation (70 kW_e, a predicted reduction of 6.0 and 3.4 % by the MATLAB[®] and Aspen[®] model at an injected steam fraction of 8 %) compared to full load operation (0.04 and 0.3 %). The impact on the MATLAB[®] model is also more significant compared to the Aspen[®] model, due to the difference in mass flow rates; however, similar trends can be observed. It is worth noticing that with higher superheating temperature, theoretically achievable by recovering the heat content of the exhaust in a HRSG, the performance of the mGT would be enhanced also in terms of electrical efficiency with increasing mass flow rate of injected steam when injecting in the combustion chamber [5].

When looking at the rotational speed (and thus the outlet pressure of the compressor), we can observe that for both injection in the compressor outlet and the combustion chamber, the rotational speed reduction is similar when considering the two models individually. This indicates that for both injection cases, the compressor operation is independent of the steam injection point, resulting in a surge margin reduction that is only function of the steam fraction (the humidity) of the working fluid. In fact, as already observed by the authors in [4], neither the injection location, nor the form in which water is injected (liquid, vapor or through a saturation tower), but only the humidity level impacts the rotational speed of the unit. When comparing the different predicted rotational speed reduction between the Aspen[®] and the MATLAB[®] model, it is clear that the reduction is more severe in for the MATLAB[®] model (e.g. an 8 % reduction at 10 % injected steam fraction at 100 kW_e for the MATLAB[®] model compared to a limited 4.4 % reduction in the Aspen[®] case), which is a result of the different simulation approach (see Table 3).

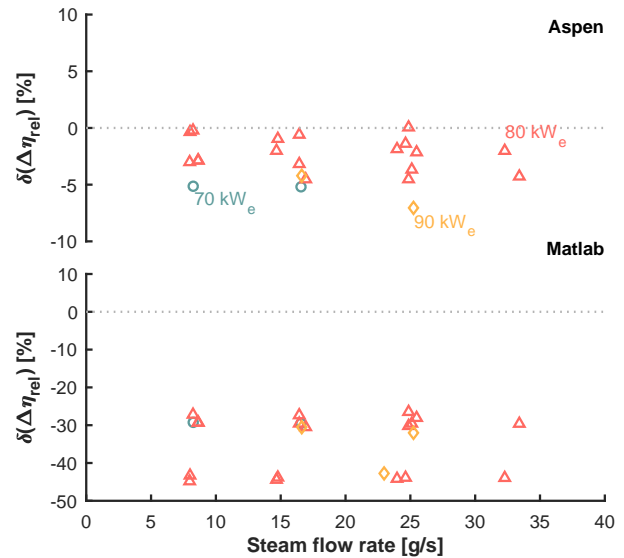

FIGURE 7. Comparison between numerical results obtained with the Aspen[®] and MATLAB[®] model and experimental results using L-gas show good agreement, validating the numerical model.

Experimental validation

The numerical models predicting the impact of steam injection in the compressor outlet on the performance of a natural gas fuelled mGT have been experimentally validated (Figure 7). Several experiments with steam injection in the compressor outlet at different steam flow rates and power outputs have been performed using L-gas. Since the impact of a given steam injection mass flow rate on the mGT performance strongly depends on the inlet air conditions (temperature and pressure, which could not be controlled during experiments) and the electrical power output settings, we opted to compare the relative difference between the measured and the simulated absolute electrical efficiency increase with the Aspen[®] and MATLAB[®] model. To obtain an accurate absolute electrical efficiency increase, rather than using the direct measurement of fuel flow rate, which introduces a very large uncertainty on the result, a so-called perturbation analysis was used. In this perturbation analysis, the absolute efficiency increase is assessed using parameters that can be measured with high accuracy, i.e. change in rotational speed and injected steam mass flow rate, allowing to limit the uncertainty on the final results [12]. Each of the experimental data points is compared with the numerically calculated efficiency, using the same inlet and operating conditions as captured during the experiments (inlet air temperature and power setting where adjusted).

The experimental validation highlights that for the considered operating points, the normalized difference between experimentally measured and simulated efficiency increase is below 5 % for the Aspen[®] model. This is an acceptable difference, taking into

account the limited impact of steam injection on the mGT operation (absolute increase in the order of several percent) and the uncertainty on the fuel flow rate (1 % on the full-scale reading). The relative difference remains constant for the different power settings and does not increase with increasing injected steam mass flow rates. Given the limited relative difference between simulations and measurements, we could conclude that the Aspen[®] model is experimentally validated. For the MATLAB[®], on the other hand, the normalized difference between simulated and experimentally measured efficiency increase is in between 25 % and 45 %, which is a result of the over-prediction of the recuperator efficiency as discussed in previous section. An experimental tuning of this efficiency should allow getting a more accurate simulation of the impact of steam injection on the mGT performance.

Due to the limitations of the experimental test rig, the validation of the impact of direct steam injection in the combustion chamber could not be directly performed. As discussed in the previous section, steam injection in the compressor outlet or in the combustion chamber has a rather different impact on the global mGT performance; however, this is a result of the particular performance of the recuperator in both cases. In the first case, steam is injected before the recuperator, leading to changing cold fluid physical properties and as consequence an increased heat recovery. In the latter case, steam is injected downstream of the recuperator cold side, thus the heat recovery remains similar to the dry case. Hence, despite the distinct impact on the global performance, in terms of simulations of the turbomachinery there is little difference between both injection modes for the compressor and turbine. From the compressor point of view, since the injection occurs in both cases downstream of this component, the working fluid remains unchanged and the compressor sees in both cases the same change in operating point because of the turbine choking. From the turbine point of view, given that the injection always occurs upstream of the turbine, the working fluid will change similarly in both cases. Although only the injection in the compressor outlet could be validated experimentally, the impact is similar on compressor and turbine in both cases. Therefore, this validation can be used to partially validate the injection in the combustion chamber (except for the changed recuperator performance).

Impact of the usage of syngas

The usage of syngas has a moderate impact on the dry performance of the mGT compared to the standard operation using natural gas (Figure 4 and Figure 5). When using syngas, a larger amount of fuel needs to be injected into the combustion chamber to reach the constant TOT. Given that the turbine is choked, the higher fuel mass flow results in a slight shift in the compressor operating point, leading to a reduction in compressor efficiency and thus a slight decrease in electrical mGT efficiency. For the MATLAB[®] model, an average shift in the electrical efficiency of 2.3 % is predicted over the simulated power range, while the

Aspen[®] model estimates a smaller 0.5 % efficiency reduction (Figure 4). With the increasing compressor inlet air temperature, we can observe that the absolute efficiency reduction when using syngas remains constant for both MATLAB[®] and Aspen[®] models (2.4 and 0.8 % at 15 °C compared to 2.2 and 0.8 % at 40 °C, Figure 5). At high inlet air temperatures, the mGT shifts towards higher rotational speeds to be able to achieve constant power output, again shifting the compressor operating point to lower efficiency regions, resulting in a lower electrical efficiency. At higher inlet air temperature, this shift becomes very large, reducing the compressor efficiency quite significantly, which explains the more severe impact. The predicted effect of syngas feed, simulated by the different models, shows again moderate agreement; however, the discrepancies can be explained by the slightly shifted dry operating point of the compressor for both models and the different model parameters tuned in the different machines.

Finally, when comparing the predicted impact of steam injection on the mGT performance using natural gas or syngas as fuel of both models, we can conclude that there is again only moderate agreement between both models for the different injection modes (Figure 6). Despite the limited concordance, we can still deduce that the general trends for full load performance are captured in a similar way. At full load, both the MATLAB[®] and Aspen[®] models predict a very limited efficiency decrease (0.3 and 0.1 % versus 0.2 and 0.7 % for both injection locations at 8 % steam fraction) and a slightly higher fuel consumption (0.3 and 0.1 % versus 0.2 and 0.8 %) compared to the natural gas fired mGT. At part load; however, we observe the opposite behaviour: the Aspen[®] model predicts a performance reduction when switching to syngas, while the MATLAB[®] model indicates an efficiency increase, which is quite significant when steam is injected in the combustion chamber (1.5 %). The different behaviour can be explained by the discrepancies in the dry performance simulations (Figure 4): while the Aspen[®] model only predicts a limited reduction of the mGT efficiency when switching from natural gas to syngas (less than 0.5 %), the MATLAB[®] model indicates a more severe 2 % reduction. Both models use thus a different dry reference operating point, of which the MATLAB[®] operating point is diverted most from the design conditions. Given the significant higher fuel mass flow rate injected in the combustion chamber, a rather large shift in compressor operation performance can be expected. Depending on the reference point, the compressor performance can differ quite significantly (Figure 2(a)), explaining the different behaviour. Additionally, no significant difference can be observed in the relative change in rotational speed, nor between injection before or after the recuperator, neither between usage of syngas and natural gas. The main impact of using an alternative fuel, such as syngas, will be found in the combustion chamber leading to different exhaust gas emissions. The analysis of these exhaust gasses is however outside the scope of this paper, but is nevertheless important when performing steam injection in an mGT.

CONCLUSION

In this paper, an advanced simulation model, predicting the impact of steam injection in two different locations (in the compressor outlet and in the combustion chamber) on the mGT performance, has been compared with a typical steady-state numerical model of the steam injected mGT cycle, and validated experimentally. The advanced model is an in-house MATLAB[®] model using the NIST database to calculate the working fluid properties together with a more advanced insight in the behaviour of the thermo-fluid dynamics of the turbomachines and of the gas composition, using the Gri-MEch 3.0 library. The validation model was developed in Aspen[®] plus, using more advanced property methods to calculate the different properties of the working fluid, but uses a simple model for the combustion chamber. The aim of this paper was to compare the predicted impact of the steam injection at the different locations on the mGT performance from the MATLAB[®] model with the typical steady-state Aspen[®] model and to validate it experimentally. This validated advanced model, which is not only capable of predicting correctly the cycle performance, but could also handle the complex chemical kinetics in the combustion chamber, would allow for a more in-depth study of steam injection in mGT cycles towards more operational and fuel flexibility.

Comparison of the numerical results when using natural gas showed some differences between the models (5.9 and 0.4 % on average for the efficiency increase over the full simulated steam injection rate at nominal power output for respectively injection in the compressor outlet and in the combustion chamber); however, the general trends are captured in a similar way. Additionally, the numerical results of steam injection in the compressor outlet of both models were also validated with steam injection experiments in a T100, indicating that the advanced MATLAB[®] model overpredicts the efficiency improvement by 25 % to 45 %. A second comparison for syngas utilization in the combustion chamber showed again some variation between both models (5.8 and 0.9 %). The results show the potential of simulating the humidified cycle using more advanced models; however, in future work, special attention should be paid to the experimental tuning of the model parameters in general and the recuperator performance in particular to allow correct assessment of the cycle performance.

FUTURE WORK

In a next step, both models will be evaluated in more detail, focusing more on the combustion modelling and in particular the produced emissions during steam injection, especially with the MATLAB[®] model, which allows for a more in-depth study of the exhaust gas composition. This next step will also include a more in-depth experimental validation of the steam injection, focussing on injection in the combustion chamber.

REFERENCES

- [1] International Energy Agency (IEA), 2014. Energy, climate changed & environment: 2014 insights. Tech. rep., International Energy Agency (IEA).
- [2] European Environment Agency (EEA), 2013. Combined Heat and Power (CHP) (ENER 020) - Assessment, November. Online available: <http://www.eea.europa.eu/data-and-maps/indicators/combined-heat-and-power-chp-1/combined-heat-and-power-chp-2> (accessed: 19-08-2014).
- [3] Delattin, F., Bram, S., Knoop, S., and De Ruyck, J., 2008. "Effects of steam injection on microturbine efficiency and performance". *Energy*, **33**(2), pp. 241 – 247.
- [4] De Paepe, W., Montero Carrero, M., Bram, S., Contino, F., and Parente, A., 2017. "Waste heat recovery optimization in micro gas turbine applications using advanced humidified gas turbine cycle concepts". *Applied Energy*, **207**, pp. 218–229.
- [5] Renzi, M., Patuzzi, F., and Baratieri, M., 2017. "Syngas feed of micro gas turbines with steam injection: Effects on performance, combustion and pollutants formation". *Applied Energy*, **206**, pp. 697 – 707.
- [6] Renzi, M., Riolfi, C., and Baratieri, M., 2016. "Influence of the syngas feed on the combustion process and performance of a micro gas turbine with steam injection". *Energy Procedia*, **105**, pp. 1665–1670.
- [7] Jonsson, M., and Yan, J., 2005. "Humidified gas turbines – A review of proposed and implemented cycles". *Energy*, **30**(7), pp. 1013 – 1078.
- [8] De Paepe, W., Montero Carrero, M., Bram, S., Parente, A., and Contino, F., 2017. "Towards higher micro gas turbine efficiency and flexibility — Humidified mGTs: A review". *Journal of Engineering for Gas Turbines and Power*. (Accepted for publication: GTP-17-1371, 10.1115/1.4038365).
- [9] Lee, J. J., Jeon, M. S., and Kim, T. S., 2010. "The influence of water and steam injection on the performance of a recuperated cycle microturbine for combined heat and power application". *Applied Energy*, **87**(4), pp. 1307 – 1316.
- [10] Mochizuki, K., Shibata, S., Inoue, U., Tsuchiya, T., Sotouchi, H., and Okamoto, M., 2005. "New concept of a micro gas turbine based co-generation package for performance improvement in practical use". In ASME Conference Proceedings, no. ASME Paper PWR2005-50364, pp. 1305–1310.
- [11] Stathopoulos, P., and Paschereit, C., 2015. "Retrofitting micro gas turbines for wet operation. a way to increase operational flexibility in distributed CHP plants". *Applied Energy*, **154**, pp. 438 – 446.
- [12] De Paepe, W., Delattin, F., Bram, S., and De Ruyck, J., 2012. "Steam injection experiments in a microturbine – A thermodynamic performance analysis". *Applied Energy*, **97**,

- pp. 569 – 576.
- [13] De Paepe, W., Delattin, F., Bram, S., Contino, F., and De Ruyck, J., 2013. “A study on the performance of steam injection in a typical micro Gas Turbine”. In ASME Conference Proceedings, no. ASME paper GT2013-94569, p. V05AT23A011.
- [14] Ferrari, M. L., Pascenti, M., Traverso, A. N., and Massardo, A. F., 2012. “Hybrid system test rig: Chemical composition emulation with steam injection”. *Applied Energy*, **97**, pp. 809 – 815.
- [15] Renzi, M., Caligiuri, C., and Rossi, M., 2017. “Micro-gas turbine feed with natural gas and synthesis gas: Variation of the turbomachines operative conditions with and without steam injection”. In ASME Conference Proceedings, no. ASME paper GT2017-63801, p. V008T26A011.
- [16] Loujendi, D., Sani, K., Tofigh, A., Majidian, A., and Jouybari, H., 2012. “An economical evaluation of the water/steam injection in a CHP microturbine cycle”. *Journal of Engineering Science and Technology Review*, **5**(2), pp. 20–25.
- [17] Stathopoulos, P., and Paschereit, C. O., 2015. “Operational strategies of wet cycle micro gas turbines and their economic evaluation”. *Journal of Engineering for Gas Turbines and Power*, **138**, p. V003T20A003.
- [18] Turbec AB, 2000-2001. *T100 microturbine CHP system: Technical description ver 4.0*.
- [19] Renzi, M., Caresana, F., Pelagalli, L., and Comodi, G., 2014. “Enhancing micro gas turbine performance through fogging technique: Experimental analysis”. *Applied Energy*, **135**, pp. 165 – 173.
- [20] Developers, C., 2017. Cantera — chemical kinetics - thermodynamics - transport processes. Available online: <http://www.cantera.org/docs/sphinx/html/index.html>.
- [21] Berkeley, University of California, 2000. Gri-mech 3.0. Online available: <http://combustion.berkeley.edu/gri-mech/index.html> (accessed: 10-11-2015).
- [22] Aspen Technology Inc., 2017. Aspen plus v9.0. Online available: www.aspentech.com (accessed: 29-01-2018).
- [23] De Paepe, W., Montero Carrero, M., Giorgetti, S., Parente, A., Bram, S., and Contino, F., 2016. “Exhaust gas recirculation on humidified flexible micro gas turbines for carbon capture applications”. In ASME Conference Proceedings, no. ASME paper GT2016-57265, p. V003T06A011.
- [24] De Paepe, W., Delattin, F., Bram, S., and De Ruyck, J., 2013. “Water injection in a micro gas turbine – Assessment of the performance using a black box method”. *Applied Energy*, **112**, pp. 1291–1302.
- [25] Parente, J., Traverso, A., and Massardo, A. F., 2003. “Micro humid air cycle: Part A – Thermodynamic and technical aspects”. In ASME Conference Proceedings, no. ASME paper GT2003-38326, pp. 221–229.
- [26] Lagerström, G., and Xie, M., 2002. “High performance and cost effective recuperator for micro-gas turbines”. In ASME Conference Proceedings, no. ASME paper GT2002-30402, pp. 1003–1007.
- [27] De Paepe, W., Montero Carrero, M., Bram, S., and Contino, F., 2014. “T100 micro gas turbine converted to full humid air operation: Test rig evaluation”. In ASME Conference Proceedings, no. ASME paper GT2014-26123, p. V03AT07A020.
- [28] Comodi, G., Renzi, M., Caresana, F., and Pelagalli, L., 2015. “Enhancing micro gas turbine performance in hot climates through inlet air cooling vapour compression technique”. *Applied Energy*, **147**(0), pp. 40 – 48.