

Control of luminescence in conjugated polymers through control of chain microstructure

W. James Feast,^{*a} Franco Cacialli,^{*b} Alex T. H. Koch,^c Rusli Daik,^a Christine Lartigau,^a Richard H. Friend,^c David Beljonne^d and Jean-Luc Brédas^e

Received 23rd October 2006, Accepted 27th November 2006

First published as an Advance Article on the web 12th December 2006

DOI: 10.1039/b615408p

The development of semiconducting polymers with high solid-state luminescence efficiencies has enabled the fabrication of efficient polymer light-emitting diodes. Luminescence is often quenched in well-ordered molecular solids, as a result of inter-molecular dipolar coupling, and the general observation of efficient luminescence in semiconducting polymers is unexpected. We report here the synthesis and characterisation of a series of model 'glassy' poly(arylenevinylene)s where we control the *cis* to *trans* ratio about the vinylene linkage and also the phenylene linkage geometry. Photoluminescence efficiency is enhanced for more disordered materials, with highest values for 50 : 50 *cis* : *trans* ratios, when it exceeds 50%. We also find that the free volume associated with these glassy disordered polymers allows conformational relaxation of the excitonic state, *via* ring rotation at the vinylene linkage, causing a large Stokes' shift of the emission. We propose that high luminescence efficiency in these glassy polymers is due to emission from the more disordered regions, and that two effects due to disorder are simultaneously required: firstly that these regions are luminescent (prevention of aggregation by disorder), and, secondly, that the electronic excited state (exciton) can lower its energy below its value in more ordered regions by means of the ring-rotational coupling.

Introduction

Conjugated organic polymers are of interest in the field of materials for solid-state electronics¹ since they can be solution-processed, and because the techniques of synthetic organic chemistry can be employed to generate a large variety of structures.² The use of these semiconductors in device configurations has been demonstrated in light-emitting diodes (LEDs),³ field-effect transistors,⁴ optically pumped lasers,⁵ sensors,⁶ photovoltaic cells⁷ and logic circuitry.⁸ All these applications place emphasis on the requirement for precision and control in synthesis and manipulation of such materials.⁹

Poly(arylene vinylene)s, PAVs, have been known for many years^{10,11} and proved suitable for use as active layers in polymer based LEDs,³ particularly poly(*p*-phenylene vinylene),

PPV and its derivatives.¹² Normally PPV is obtained *via* a precursor route which involves the synthesis of a solution processable soluble polyelectrolyte that is converted to PPV by pyrolysis in the solid state. The route has been intensively developed so as to provide access to a wide range of PAVs. For example, it has been shown that manipulation of the leaving group allows the introduction of *cis*-vinylene units into PPV and that, qualitatively, this results in improved emission efficiency,¹³ possibly *via* the introduction of disorder into the active films. In addition to the precursor routes, extensive use is made of PAVs, which are made directly soluble by the attachment of suitable side-groups. Spreitzer *et al.* have reported a range of such co-polymers which can be used to fabricate LEDs with luminous efficiencies of up to 16 lm W⁻¹.¹⁴ The effects of disorder have also been studied for these soluble polymers; the presence of *cis* linkages affects the efficiency of emission in *meta*-linked PAVs such as poly(*m*-phenylenevinylene-co-2,5-dioctoxy-*p*-phenylenevinylene).¹⁵

The high efficiencies obtained for electroluminescent diodes made with conjugated polymers are only possible if the emissive polymers show high efficiencies for radiative emission from the exciton formed by electron-hole capture. This is conveniently measured directly from the photoluminescence, PL, and the better-performing materials show PL efficiencies of at least 50%.¹⁶ However, high PL efficiency is not generally found in solid molecular semiconductors, because intermolecular contacts modify the nature of the exciton so that the radiative emission rate is strongly decreased. This is described classically in terms of the formation of physical aggregates, which are known to quench the luminescence through the interaction of the excited-state dipole moments on adjacent

^aDepartment of Chemistry, University of Durham, UK DH1 3LE.

E-mail: W.J.Feast@durham.ac.uk; Fax: +44 (0)191 374 4651;

Tel: +44 (0)191 374 4651

^bDepartment of Physics and Astronomy, and London Centre for Nanotechnology, University College London, Gower Street, London, UK WC1E 6BT. E-mail: f.cacialli@ucl.ac.uk; Fax: +44 (0)20 7679 1360;

Tel: +44 (0)20 7679 4467

^cThe Cavendish Laboratory, JJ Thomson Avenue, Cambridge, UK

CB3 0HE. E-mail: rhf10@cam.ac.uk; Fax: +44 (0)1223 353 397;

Tel: +44 (0)1223 337 218

^dService de Chimie des Matériaux Nouveaux, Centre de Recherche en Electronique et Photonique Moléculaires, Université de Mons-Hainaut, 20, Place du Parc, B-7000, Mons, Belgium.

E-mail: David@averell.umh.ac.be; Fax: +32 (0)65 37 38 61;

Tel: +32 (0)65 37 38 67

^eSchool of Chemistry and Biochemistry, Georgia Institute of Technology, 770 State Street, Atlanta, Georgia, 30332-0400, USA.

E-mail: jean-luc.bredas@chemistry.gatech.edu;

Fax: +1 (1)404 894 7452; Tel: +1 (1)404 894 4002

sites. Quenching arises when the lower energy configuration has antiparallel dipoles, as is energetically expected for parallel alignment of adjacent molecules.¹⁷ For PPV, a description in terms of inter-chain charge transfer has also been developed by Rothberg *et al.*¹⁸ Absolute PL efficiencies are measured using an integrating sphere technique^{1,19} and for the PAVs, values for precursor-route PPV of 27% and for poly(2-methoxy-5-(2'-ethyl-hexyloxy)-*p*-phenylenevinylene), MEH-PPV, of 10–15% are found.^{1,20} These values probably indicate some quenching of PL through inter-chain interactions in the solid.²¹ Considerably higher values are found for more disordered polymers; the reasons for this are not straightforward, as we investigate and explain below.

The introduction of disorder in the solid state packing through the use of co-polymers was shown to improve electroluminescent efficiency.²² The explanation proposed for this observation was that disorder restricted the exciton diffusion range, and thus reduced the chance of finding a non-radiative decay site.²³ However, the effect of disorder on aggregate formation also needs to be considered. Cornil *et al.*²⁴ have calculated the interaction between cofacial PPV oligomers and found that substantial effects are expected at an intermolecular separation of 7 Å or less. Dimer or aggregate formation leads to the splitting of the frontier orbitals, with the lower energy transition, which should be symmetry forbidden, becoming partially allowed due to asymmetric geometric relaxation of the 2 molecules in the excited state. This approach is amenable to the study of the effects of chain length and positional disorder. Cornil *et al.* concluded that (i) PL quenching can be decreased for well-ordered long chains, and, (ii), changes in the orientation of the molecules (*e.g.* perpendicular to one another) or of the dihedral angles between the planes of the molecules break symmetry and therefore prevent the PL quenching. For disordered polymers which show little evidence of crystallinity, mechanism (ii) can provide part of the sample within which inter-chain interactions are favourable for radiative emission. The problem however, is that there will also be regions in which the inter-chain interactions lower the excited state energy and quench emission. These regions might be expected therefore to act as quenching centres. However, as we discuss below, we consider that excitons in the disordered regions are able to lower energy *via* rotation about the C–C bond of the vinylene moieties, making use of the free volume found in glassy polymers—a process which is less accessible to excitons in ordered regions. By this means, energy transfer is from ordered to disordered regions, and efficient luminescence is achieved. We note that such transfer can take place, by whatever means available (*e.g.* Förster or tunnelling), directly to the lowest energy excited state (relaxed conformation). This is no different to the standard description for vibrational coupling to electronic excitations using Huang–Rhys parameters. So long as the transfer rate is fast in comparison to the radiative decay rate, the transfer will appear to be complete.

Results

We have focused attention on a family of PAVs within which it is possible to control disorder (through control of the *cis* to *trans* vinylene ratio) and which also provide models for the

investigation of the effects of torsion between the phenyl and vinyl moieties (through the study of *meta*-linked polymers). We have previously reported a route to a PAV namely, poly(4,4'-diphenylene diphenylvinylene) (PDPV), using the McMurry coupling of a diketone, Fig. 1, pathway (ia). This polymer is soluble and easily processible.^{11,25} Although PDPV showed high luminescence efficiency (45%), it was not possible to make a correlation with the chain structure since the *cis* : *trans* vinylene frequency and distribution could not be determined. We have now solved this problem using new routes (Fig. 1, pathway (ii) and (iii)) to the same basic polymer structure, but in which the *cis* : *trans* vinylene distribution can be controlled. Details about the synthetic route are reported in the Experimental section.

Fig. 2A reports the UV-vis spectra for thin films of poly(tetra-*para*-phenylene diphenylvinylene)s from fractions with different *cis* contents and different molecular weights (in parentheses in the Figure). For each spectrum we can decompose the first absorption feature (π – π^* transition) into one peak at approximately 360 nm, and another component at about 310 nm, the weight of which increases (310 nm) or decreases (360 nm) with increasing *cis* content in the fraction, irrespective of the molecular weight. This observation is consistent with the expectation of reduced conjugation, and hence of a larger energy gap, for the *cis*-linked PAV segments as compared to the *trans*-linked, chain-extended segments. Therefore we can consider the ratio of these two bands as indicative of the *cis* : *trans* content. Good evidence that the incorporation of *cis* residues is not significantly affected by the molecular weight is provided by the virtually identical thin film UV-vis spectra (not shown) of different fractions with the same nominal *cis* content (32%) but different molecular weights (M_n = 2800, 8300 and 16300).

Table 1 records photoluminescence (PL) efficiency data for a set of poly(tetra-*para*-phenylene diphenylvinylene)s which show that the *cis* : *trans* content has a marginal effect on the photoluminescence emission wavelength, but has a very marked effect on the solid state photoluminescence efficiency, which peaks at a *cis* : *trans* ratio of about 50 : 50 in this polymer.

The photoluminescence efficiency for poly(tetra-*para*-phenylene diphenylvinylene)s with an all *cis* or all *trans* vinylene content is about half that of the analogous system with a roughly 50 : 50 *cis* : *trans* ratio. We observe a reduction in luminescence efficiency with increasing molecular weight, for this polymer (*e.g.* for the 32% *cis* fraction PL efficiencies of 32.5% and 21.7% were observed for M_n values of 8300 and 16 300 respectively). Similar effects were observed for PDPV synthesised by the Yamamoto route, Fig. 1, pathway (ii), and for poly(1,3-phenylene diphenylvinylene)s made by the McMurry route. This reduction in efficiency correlates with a red-shift in the PL spectra. Indeed the evolution of the PL spectra as shown in Fig. 2B suggests that variations in molecular weight may be marginally more important than those in the *cis* : *trans* content in determining the spectral shapes and positions, although the effect is small. With the exception of the data for the 48% *cis* fraction (M_n = 4200), we observe a small red-shift of the spectrum with increasing molecular weight. This trend was confirmed by measurements

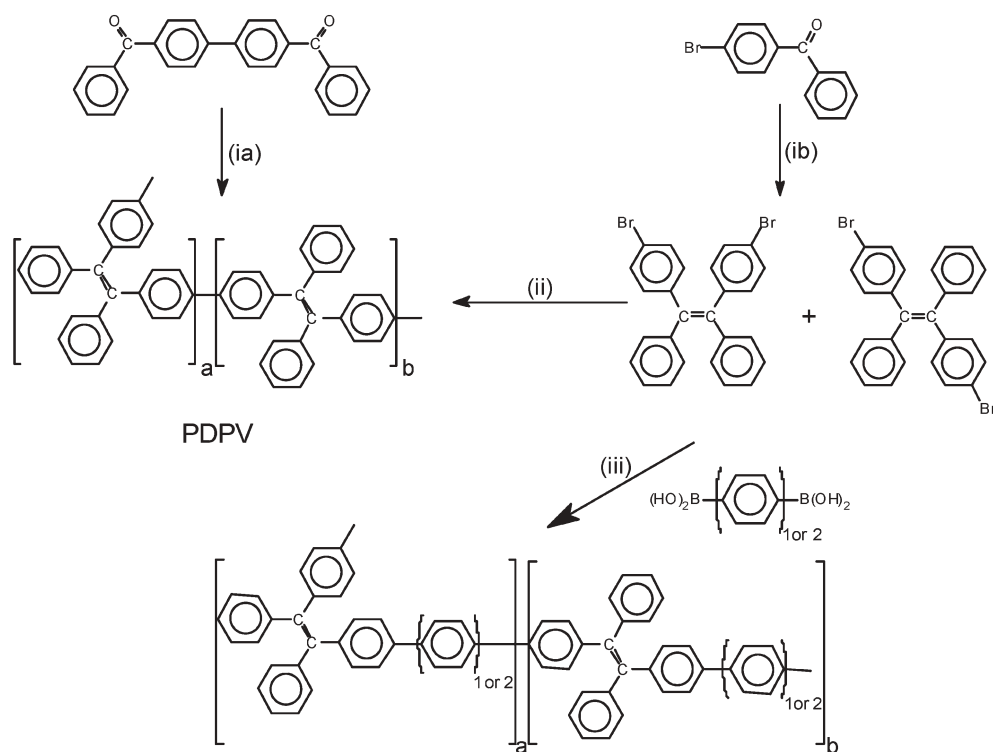

Fig. 1 Scheme outlining the routes to the poly(arylene vinylene)s discussed in this paper. Routes (ia and ib), McMurry coupling, $\text{TiCl}_3\text{-LiAlH}_4\text{-THF}$; (ii) Yamamoto coupling, $\text{Mg-Ni}(\text{PPh}_3)_2\text{Cl}_2\text{-THF}$; (iii) Suzuki coupling $\text{Pd}(\text{PPh}_3)_4\text{-K}_2\text{CO}_3\text{-THF-H}_2\text{O}$.

for three samples with the same *cis* content (32%) and different molecular weights. We consider that the absence of a blue-shift for the emission with increasing *cis* content is accounted for by spectral diffusion of excitons to lower-energy sites, associated with *trans*-sequences. We consider, furthermore, that as the molecular weight is increased, the statistical arrangement of larger numbers of adjacent *trans*-sequences accounts for the red-shift in emission, which is due to spectral diffusion to these sections of the polymer chain.

Discussion

The PAVs studied here are disordered glasses at room temperature, showing glass transitions at temperatures between 180 and 250 °C. These materials therefore provide a good model system for examining the effects of microstructure defined here by the *cis* : *trans* ratio. The results show very clear evidence for enhanced luminescence efficiency in the most disordered material (50 : 50 *cis* : *trans*) where it reaches above 50%. This provides clear guidance for the design of luminescent polymers for use in LEDs. We note that *cis* structures can also exist with an ordered “zig-zag arrangement” of the repeat units. Another reason for the decrease of PL efficiency at high *cis* content may be that highly coiled *cis* structures are more difficult to free from traces of catalyst residues and other quenching impurities.

One of the most surprising features of the PL spectra is the very significant red-shift of the emission with respect to absorption (the Stokes' shift), which cannot be accounted for by spectral diffusion, and persists also for excitation below

the localisation threshold in site-selective photoluminescence experiments. In order to investigate the effect of the relaxation of the molecular geometry we turned to a *meta*-linked, phenylated PAV, in the form of poly(3,3'-phenylene diphenylvinylene), m2-PPV-DP (Fig. 3A, upper panel), synthesised by the McMurry route.²⁶ This material provides an excellent model system as it is well established that the *meta*-linkage interrupts the $\pi\text{-}\pi^*$ conjugation thereby allowing description of the electronic properties of the polymer on the basis of those of the repeat unit (tetraphenylethylene, TPE, in the present case). We find that the emission and absorption spectra of this polymer does not undergo any spectral shift when passing from solid state to a chloroform solution at room temperature (not shown). The absorption and emission spectra of the model compound, TPE, are also shown in Fig. 3A, lower panel, both in solution and in the solid state. The solution spectra of the model compound are very close to those of the polymer, but in contrast to the situation for the polymer, absorption is red-shifted and emission is blue-shifted for TPE on going from solution to the solid (crystalline) state. With the help of quantum chemistry AM1 (Austin Model 1) INDO/SD-CI (intermediate neglect of differential overlaps/single and double configuration interaction), we are able to confirm that these peculiar properties derive from different degrees of steric hindrance relating to different conformations of the model in the solution and solid states. In particular we found that for TPE single molecules the excited state optimised geometry is characterised by a 60° rotation along the axis of the double bond (vinyl moiety) of half of the molecule with respect to the other half, and that inhibition of this rotation, as expected in

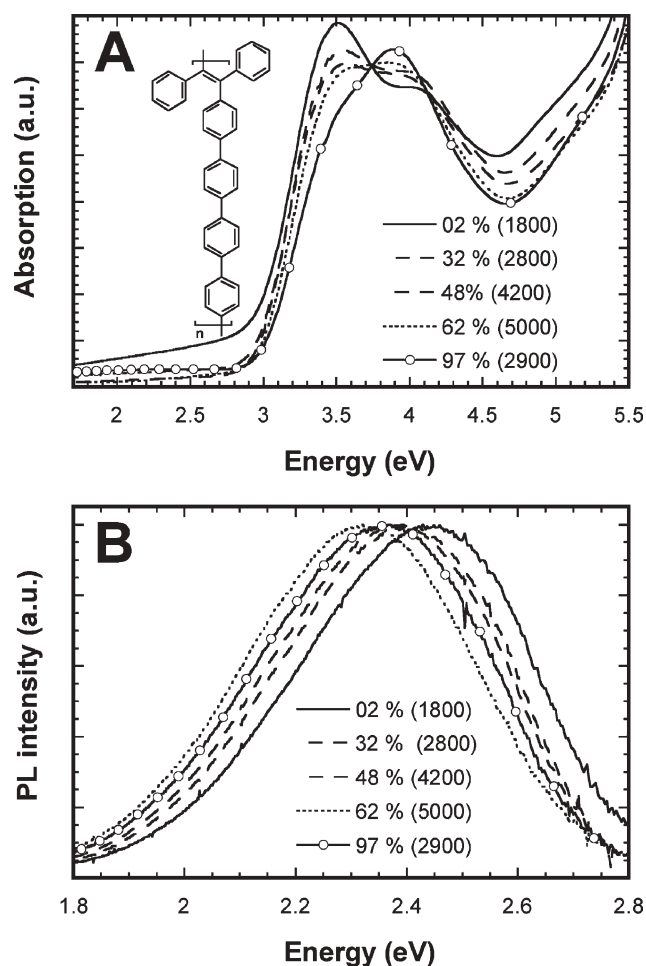

Fig. 2 (A) UV-vis absorption spectra of thin films of poly(tetra-*p*-phenylene diphenylvinylene) on spectrotil substrates. Note that the component centred at 3.44 eV (~ 360 nm) decreases with increasing *cis* content. Scattering from the 2% *cis* thin film was more important than for the other samples. (B) PL spectra of the same thin films as in (A). Films are from fractions with different number average molecular weights (in parentheses in the Figure) and different *cis* : *trans* content. All the spectra are normalised with respect to the maximum.

Table 1 Photoluminescence data for poly(tetra-*p*-phenylene diphenylvinylene)s with different *cis* : *trans* ratio

Sample	<i>cis</i> -Vinylene content (%)	M_n	Photoluminescence	
			Efficiency (%)	λ_{\max}/nm
1	97	2900	28.6	524
2	62	5000	30.1	533
3	48	4200	53.5	520
4	32	2800	35.8	521
5	2	1800	30.7	506

the solid state, widens the gap between the excited and ground state thereby accounting for the PL blue shift. In addition, the ground state optimised geometry does not display any rotation around the axis of the double bond (consistent with the planar character of the vinyl moiety in the ground state), although the ground state energy is minimum for a phenyl twist angle of $\sim 60^\circ$ which tend to give to the molecule a “propeller” shape. Inhibition of the rotation of the phenyls with respect to the

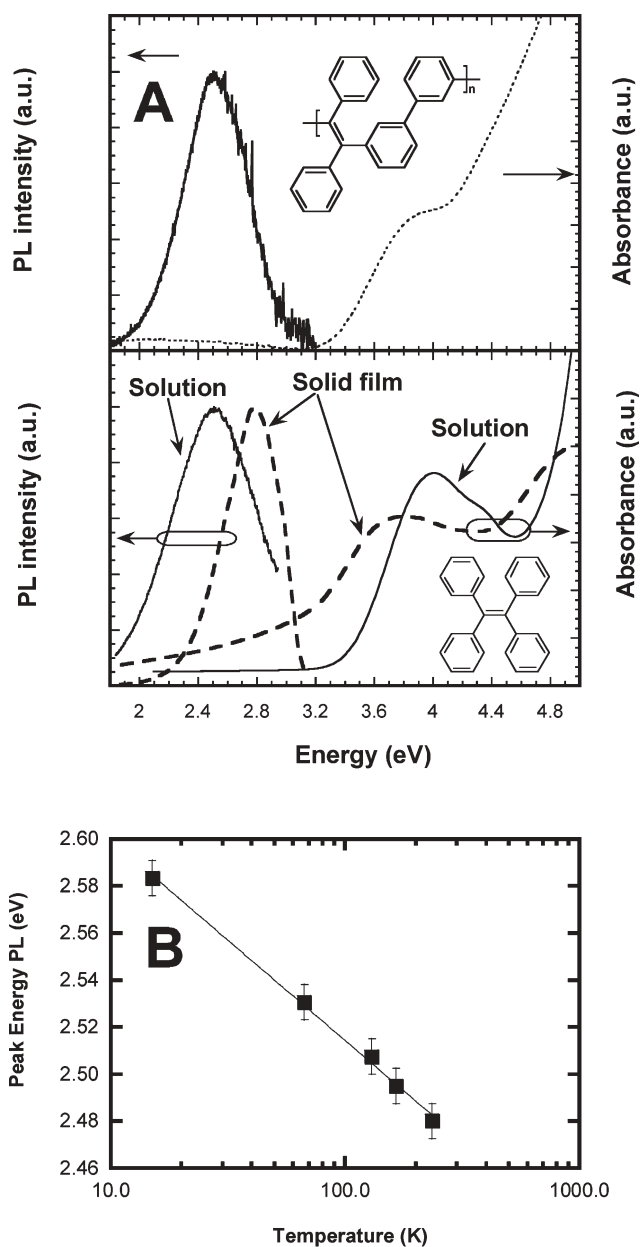

Fig. 3 (A) Absorption and emission spectra of poly(3,3'-phenylene diphenylvinylene), m2-PPV-DP (upper panel), and for tetraphenylethylene, TPE (lower panel). (B) Shift of the PL emission of thin films of poly(1,3-phenylene diphenylvinylene), m-PPV-DP, with the temperature.

plane of the double-bond leads to higher-energy ground states, and lower-energy excited states, thereby accounting for the observed red-shift of the absorption in the solid state.

The fact that for the polymers, the absorption does not display any shift when passing from solution to the solid state²⁶ is an indication that crystallisation is inhibited by the macromolecular nature of the material, so that there is sufficient free volume available to the molecule to allow geometric relaxation to the most favourable configuration, at least at room temperature. We find that this conformational freedom is reduced on cooling below room temperature, and

results in a blue shift of the PL emission as in Fig. 3B, in contrast with the red-shift reported for more ordered polymers such as PPV.²⁷

Coupling of rotation about the vinylene linkage to the electronic excited state, which becomes important when the polymer is in solution or in a non-crystalline state, is of general importance. Firstly, it is necessary to obtain high PL efficiency in solid films of disordered polymers of this type. Excitons in the disordered regions would be expected to be higher in energy than in ordered regions, but are able to lower their energy through ring torsional coupling. We therefore associate high PL efficiency in glassy polymers with the combined effects of (i) disorder-hindering of aggregation and (ii) ring-torsion coupling. Secondly, it provides a design rule for the selection of polymers for use in LEDs. PAVs provide red to green emission, but not blue, because the Stokes' shift is found to be large for the larger-gap PAVs reported. (Blue emitters are better obtained using polymers which avoid a vinylene linkage in the polymer chain, and which have extra chain rigidity imposed by formation of a 'ladder' structure, at least in part, along the chain. These include 'ladder' poly(phenylene)s²⁸ and the poly(fluorene)s.²⁹) Thirdly, it may provide insight into the investigations of the charged excited states in polyaniline, for which a model was developed by Epstein and co-workers of charged polarons localised by phenylene ring rotation about the nitrogen coupling sites.³⁰ We note that the importance of a non-crystalline environment for such rotations to be strongly coupled to the electronic excitations should not be limited to charge neutral states, such as those investigated in our work. Therefore we suggest that it is likely that these excitations on the polyaniline chain are present in the non-crystalline regions of the material (which is found to show both amorphous and crystalline components).

Experimental

Starting with 4-bromobenzophenone, McMurry coupling gave a mixture of *cis*- and *trans*-4,4'-dibromotetraphenylethenes, Fig. 1, pathway (ib), which were separated by fractional crystallisation and unambiguously identified by X-ray crystallography.³¹ These stereochemically defined 4,4'-dibromotetraphenylethenes were then used as monomers in Yamamoto, Fig. 1, pathway (ii), and Suzuki, Fig. 1, pathway (iii), coupling reactions to generate a family of PAVs, including PDPV, in which control over the *cis* : *trans* vinylene content and the size and geometry of the arylene repeat units was achieved.³²

Since all the monomers in the feed were incorporated into the polymer, control over the frequency of *cis* and *trans* vinylene units in the polymer backbones was obtained by selecting the ratio of *cis* to *trans* 4,4'-dibromotetraphenylethene in the feed. The as-made polymers were soluble and GPC analysis showed that they had a broad molecular weight distribution and that the highest molecular weights were obtained at a *cis* : *trans* ratio of 1 : 1. In order to reduce possible molecular weight effects on subsequent luminescence measurements, the samples were purified by equilibrium fractionation. It is possible that the as-made polymers contained molecules of the same mass but with different *cis* : *trans* contents. If so, such materials might be expected to have

different solubilities and so equilibrium fractionation might differentiate between fractions on the basis of *cis* : *trans* vinylene distribution as well as on the basis of molecular mass. There were small but significant differences in infrared and NMR spectra of the as-made polymers as a function of *cis* : *trans* content in the feed, these differences provided an analytical probe for the effects of fractionation and enabled us to determine that PDPV made *via* the McMurry route, Fig. 1, pathway (ia), had a roughly 50 : 50 *cis* : *trans* ratio. This method of analysis was sensitive enough to establish that some of the low molecular weight fractions of PDPV prepared by the McMurry route had chain end carbonyls detectable at 1660 cm⁻¹.

The solid state photoluminescence efficiencies were measured by means of an integrating sphere technique as described elsewhere,¹⁹ using two UV lines (351 and 363.8 nm) from an Ar ion laser for excitation.

Acknowledgements

We thank the Royal Society for the award of a University Research Fellowship (FC) and the National University of Malaysia for a studentship (RD). The Durham–Cambridge–Mons collaboration was supported within the framework of the European Commission Training and Mobility of Researchers programme (SELOA Network). The work in Mons was partly supported by the Belgian Federal Government "Service des Affaires Scientifiques, Techniques et Culturelles" (Interuniversity Attraction Pole PAI 4/11) and by the Belgian National Fund for Scientific Research (FNRS). DB is an FNRS Senior Research Fellow.

References

- 1 N. C. Greenham and R. H. Friend, *Solid State Phys.*, 1995, **49**, 1.
- 2 W. J. Feast, J. Tsibouklis, K. L. Pouwer, L. Groenendaal and E. W. Meijer, *Polymer*, 1996, **37**(22), 5017.
- 3 J. H. Burroughes, D. D. C. Bradley, A. R. Brown, R. N. Marks, K. Mackay, R. H. Friend, P. L. Burn and A. B. Holmes, *Nature*, 1990, **347**, 539.
- 4 A. Dodabalapur, H. E. Katz, L. Torsi and R. C. Haddon, *Science*, 1995, **269**(5230), 1560; H. Sirringhaus, N. Tessler and R. H. Friend, *Science*, 1998, **280**(5370), 1741.
- 5 N. Tessler, G. J. Denton and R. H. Friend, *Nature*, 1996, **382**(6593), 695.
- 6 D. H. Charych, J. O. Nagy, W. Spevak and M. D. Bednarski, *Science*, 1993, **261**(5121), 585; S. A. Jahnke, J. Niemann, W. Kautek, R. Bischoff, C. Pfeiffer and G. Kossmehl, *Int. J. Environ. Anal. Chem.*, 1997, **67**(1–4), 223.
- 7 M. Granström, K. Petritsch, A. C. Arias, A. Lux, M. R. Andersson and R. H. Friend, *Nature*, 1998, **395**(6699), 257.
- 8 A. R. Brown, A. Pomp, C. M. Hart and D. M. Deleeuw, *Science*, 1995, **270**(5238), 972; C. J. Drury, C. M. J. Mutsaers, C. M. Hart, M. Matters and D. M. Deleeuw, *Appl. Phys. Lett.*, 1998, **73**(1), 108; B. Crone, A. Dodabalapur, Y. Y. Lin, R. W. Filas, Z. Bao, A. Laduca, R. Sarpeshkar, H. E. Katz and W. Li, *Nature*, 2000, **403**(6769), 521.
- 9 H. Becker, H. Spreitzer, W. Kreuder, E. Kluge, H. Schenk, I. Parker and Y. Cao, *Adv. Mater.*, 2000, **12**(1), 42.
- 10 H. H. Hörhold and J. J. Opfermann, *Makromol. Chem.*, 1970, **105**, 131; R. A. Wessling, *J. Polym. Sci., Polym. Symp.*, 1985, **72**, 55.
- 11 W. J. Feast and I. S. Millichamp, *Polym. Commun.*, 1983, **24**(4), 102.
- 12 A. Kraft, A. C. Grimsdale and A. B. Holmes, *Angew. Chem., Int. Ed.*, 1998, **37**(4), 402.
- 13 S. Son, A. Dodabalapur, A. J. Lovinger and M. E. Galvin, *Science*, 1995, **269**(5222), 376.

-
- 14 H. Spreitzer, H. Becker, E. Kluge, W. Kreuder, H. Schenk, R. Demandt and H. Schoo, *Adv. Mater.*, 1998, **10**(16), 1340.
 - 15 W. Holzer, A. Penzkofer, S. H. Gong, A. Bleyer and D. D. C. Bradley, *Adv. Mater.*, 1996, **8**(12), 974.
 - 16 R. H. Friend, R. W. Gymer, A. B. Holmes, J. H. Burroughes, R. N. Marks, C. Taliani, D. D. C. Bradley, D. A. Dos santos, J. L. Bredas, M. Logdlund and W. R. Salaneck, *Nature*, 1999, **397**(6715), 121.
 - 17 M. Pope and C. E. Swenberg, *Electronic Processes in Organic Crystals*, Clarendon Press, Oxford, 1982, p. 43.
 - 18 L. J. Rothberg, M. Yan, F. Papadimitrakopoulos, M. E. Galvin, E. W. Kwock and T. M. Miller, *Synth. Met.*, 1996, **80**(1), 41.
 - 19 J. C. de Mello, H. F. Wittmann and R. H. Friend, *Adv. Mater.*, 1997, **9**(3), 230.
 - 20 J. Morgado, F. Cacialli, J. Grüner, N. C. Greenham and R. H. Friend, *J. Appl. Phys.*, 1999, **85**(3), 1784.
 - 21 F. Cacialli, J. S. Wilson, J. J. Michels, C. Daniel, C. Silva, R. H. Friend, N. Severin, P. Samori, J. P. Rabe, M. J. O'Connell, P. N. Taylor and H. L. Anderson, *Nat. Mater.*, 2002, **1**(3), 160.
 - 22 P. L. Burn, A. B. Holmes, A. Kraft, D. D. C. Bradley, A. R. Brown, R. H. Friend and R. W. Gymer, *Nature*, 1992, **356**, 47.
 - 23 N. T. Harrison, G. R. Hayes, R. T. Phillips and R. H. Friend, *Phys. Rev. Lett.*, 1996, **77**(9), 1881.
 - 24 J. Cornil, A. J. Heeger and J. L. Bredas, *Chem. Phys. Lett.*, 1997, **272**(5–6), 463.
 - 25 F. Cacialli, R. H. Friend, N. Haylett, R. Daik, W. J. Feast, D. A. Dossantos and J. L. Bredas, *Appl. Phys. Lett.*, 1996, **69**(25), 3794.
 - 26 A. T. H. Koch, D. Beljonne, N. T. Harrison, J. L. Bredas, N. Haylett, R. Daik, W. J. Feast and R. H. Friend, *Opt. Mater.*, 1998, **9**(1–4), 145.
 - 27 K. Pichler, D. A. Halliday, D. D. C. Bradley, P. L. Burn, R. H. Friend and A. B. Holmes, *J. Phys.: Condens. Matter*, 1993, **5**(38), 7155.
 - 28 J. Grüner, H. F. Wittmann, P. J. Hamer, R. H. Friend, J. Huber, U. Scherf, K. Müllen, S. C. Moratti and A. B. Holmes, *Synth. Met.*, 1994, **67**, 181.
 - 29 A. W. Grice, D. D. C. Bradley, M. T. Bernius, M. Inbasekaran, W. W. Wu and E. P. Woo, *Appl. Phys. Lett.*, 1998, **73**(5), 629.
 - 30 M. G. Roe, J. M. Ginder, T. L. Gustafson, M. Angelopoulos, A. G. Macdiarmid and A. J. Epstein, *Phys. Rev. B: Condens. Matter*, 1989, **40**(6), 4187; R. P. McCall, J. M. Ginder, M. G. Roe, G. E. Asturias, E. M. Scherr, A. G. Macdiarmid and A. J. Epstein, *Phys. Rev. B: Condens. Matter*, 1989, **39**(14), 10174; J. M. Ginder, A. J. Epstein and A. G. Macdiarmid, *Solid State Commun.*, 1989, **72**(10), 987.
 - 31 R. Daik, W. J. Feast, A. S. Batsanov and J. A. K. Howard, *New J. Chem.*, 1998, 1047.
 - 32 R. Daik, PhD Thesis, Durham University, UK, 1997.